



SIP Building Technology

Technical Specification Sheet

Table of Contents

Introduction to SIPs	2
Advantages of SIP Technology.....	3
Intended Use.....	4
SIP Construction Essentials	4
SIP Mount Essentials.....	6
Our Products.....	9
Standard Dimensions.....	10
Structural Performance.....	13
Natural Durability.....	21
Thermal Performance.....	21
Air Tightness and Ventilation.....	24
Fire Performance.....	24
Acoustic Performance.....	25
Intended Working Life and Warranty.....	25
Passports and Certificates.....	26
EU Production Facility.....	26
Contacts.....	27

Understanding Structural Insulated Panels (SIPs)

Structural insulated panels (SIPs) are a high-performance building system for residential and light commercial construction. The panels consist of an insulating foam core sandwiched between two rigid structural facings, typically oriented strand board (OSB).

One component polyurethane adhesive for structural use by **Everad** (France).

OSB is made from fast-growing, small-diameter trees that can be harvested from plantations, avoiding the need for cutting old-growth trees.

Ecopan typically uses Austria-made **EGGER OSB** panels, but not limited to and can be produced with **gypsum fibre board** skins.



EPS FOAM is a recyclable material that is completely inert in the environment, and is in fact often used as a soil additive. Producing EPS foam insulation requires less energy than producing fiberglass insulation and no CFCs are used in the process.

Ecopan typically uses EPS foam from **HIRSCH Porozell** (Austria) of different diameters.

Advantages of SIP Technology

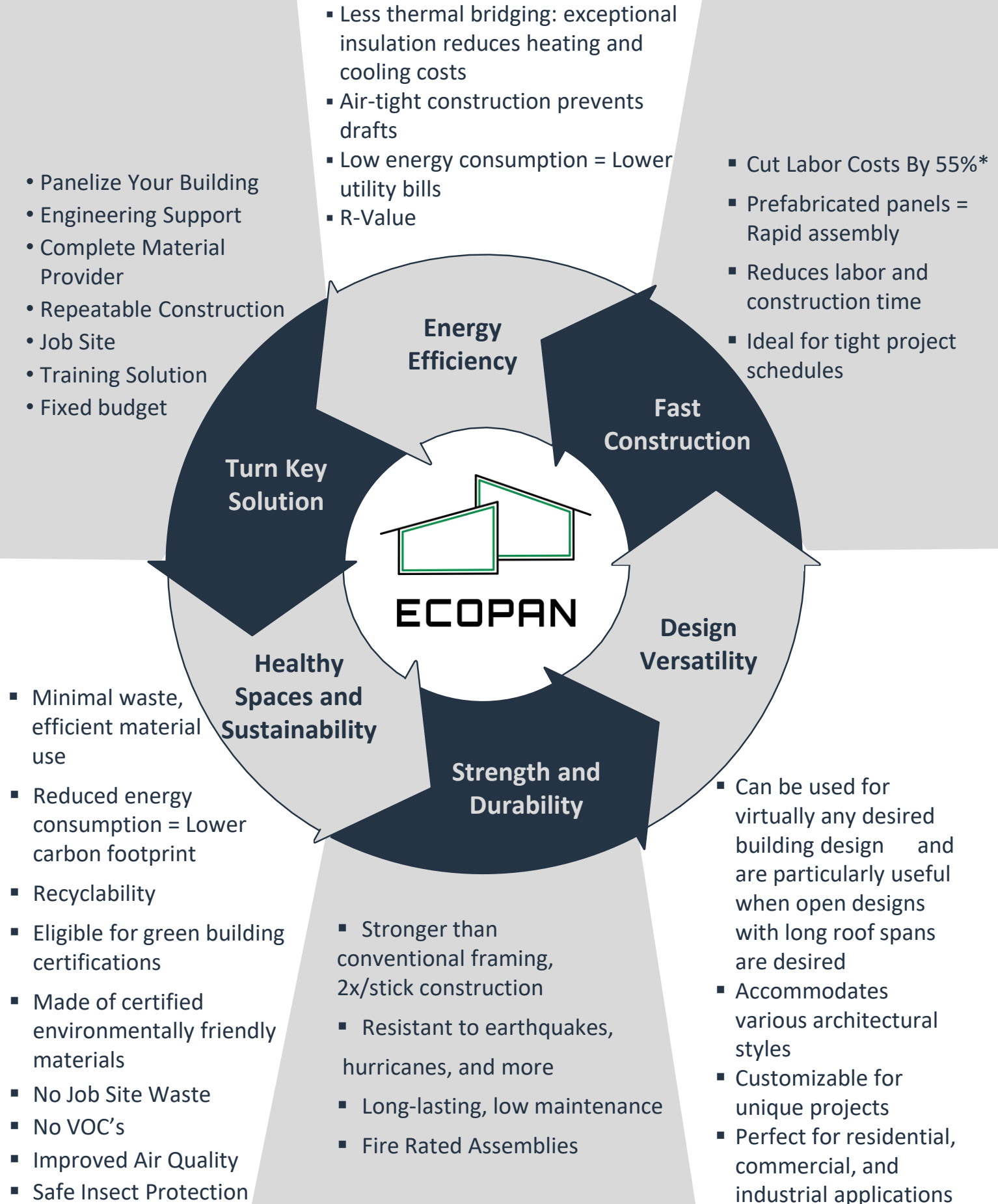

Intended Use

Ecopan panels are intended for use in **timber structures** subject to service classes 1 and 2 according to **EN 1995-1-1**.

Ecopan panels are intended for use in **single or multiple-storey constructions** as **load-bearing external walls, loadbearing internal wall, separating wall, loadbearing inner leaf of an external wall, loadbearing floor panel and loadbearing panel of flat or pitched roof**.

The product should be protected by a weather resistant outer cladding leaf when used in external walls.

Panels can be also used as infill panels to framed construction.

Suitability for the intended use is considered individually according to the standards and law regulations valid in the country of panels use.

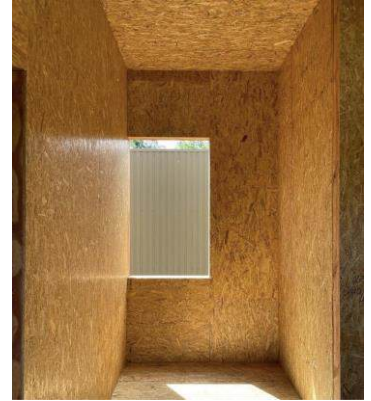

Understanding SIP Construction

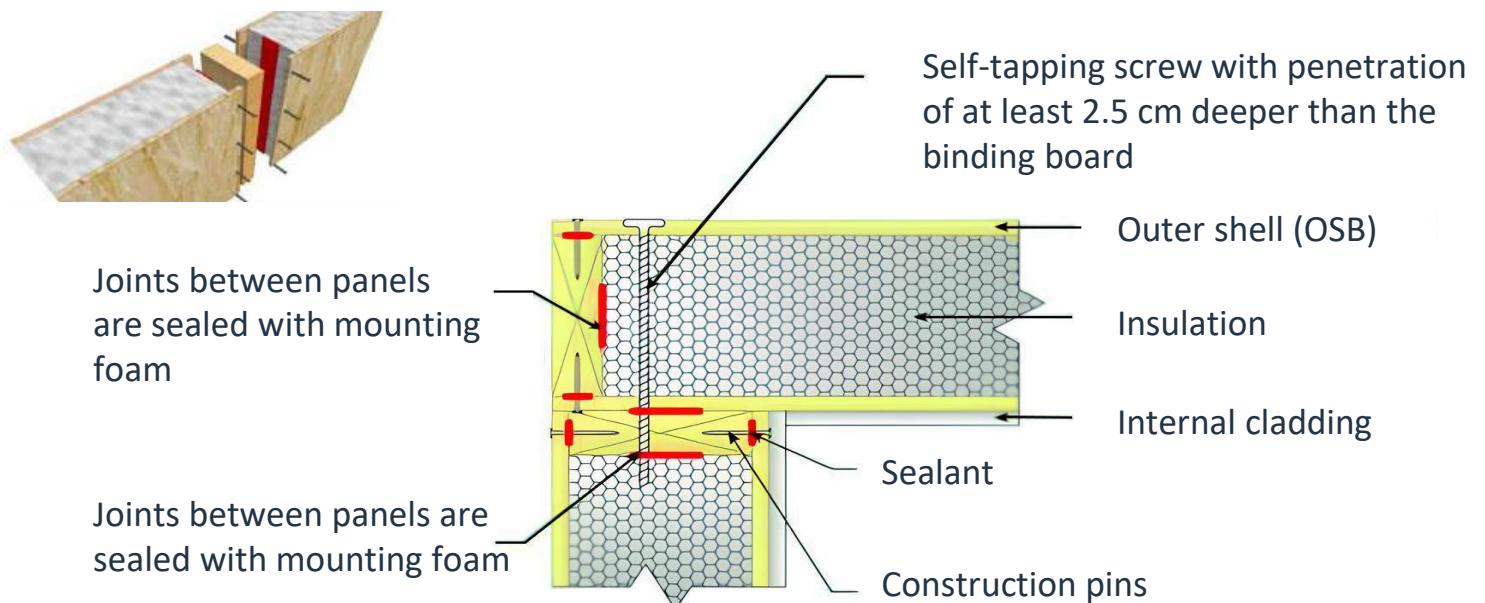

Understanding SIP Construction

Complete sections can be prefabricated to your requirements, i.e. dormer windows, porches, bay windows.

Minimized roof structure allows maximum internal space.

Excellent U value to panel thickness ratio minimizes wall thickness, thus maximizing internal space.

Eco Joists allow space for running services and provide support for next floor.

Multiple external finish options.

Load bearing partitions allow greater spans for floors.

Fully prepared apertures allow rapid erection and installation windows, thus allowing follow on trades to begin work sooner.

Air tight structure drastically reduces energy loss, thus minimising running costs of doors and completed building.

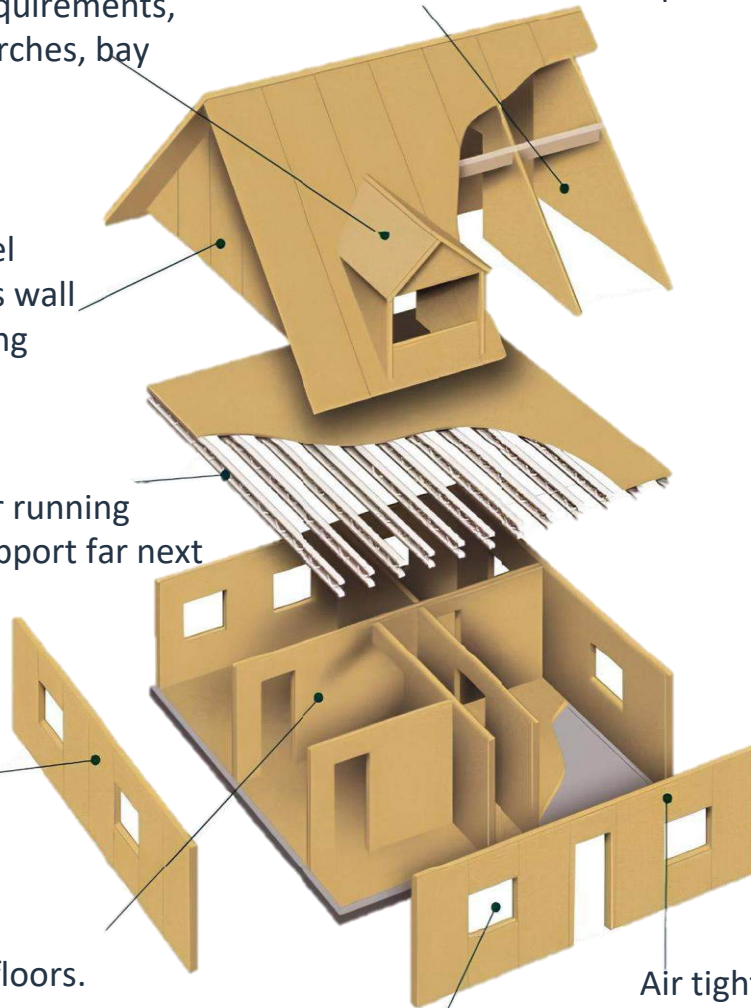

SIPs are extremely easy to connect together as part of your build, leading to a more efficient project timeline. To illustrate, tasks like roof installations, which typically span a few days, can be accomplished in a matter of hours when utilizing SIPs.

SIP construction technology involves on-site assembly as modular elements, as it shown on a figure.

After the panels are factory-fabricated, a team of workers arrives and assembles walls from pre-made blocks, followed by interior partitions floor structures and roofs

SIPs Mount Essentials

SIPs demand meticulous installation for optimal performance. Recognizing this, Ecopan not only delivers high-quality SIPs but also offers **on-site training solutions for installation teams**. We believe in empowering construction professionals with the knowledge and skills necessary to ensure precise and efficient SIP mounting. This commitment not only provides the true SIP experience but also significantly contributes to the longevity and energy efficiency of buildings constructed with Ecopan SIPs

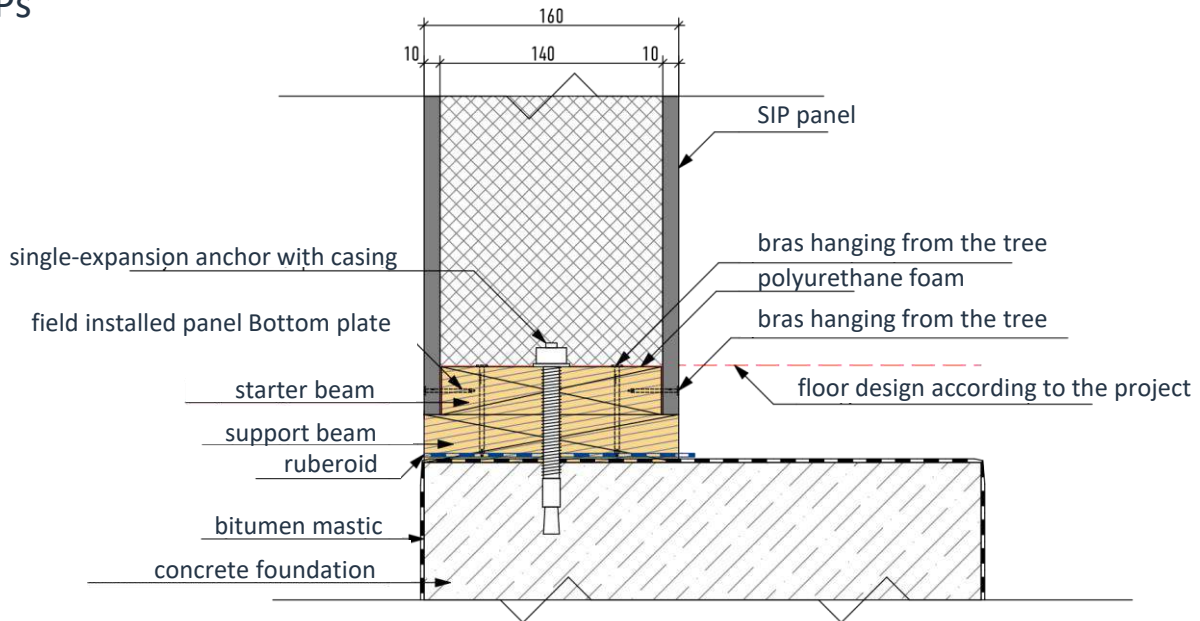

Example of panel joints to concrete or timber substructure

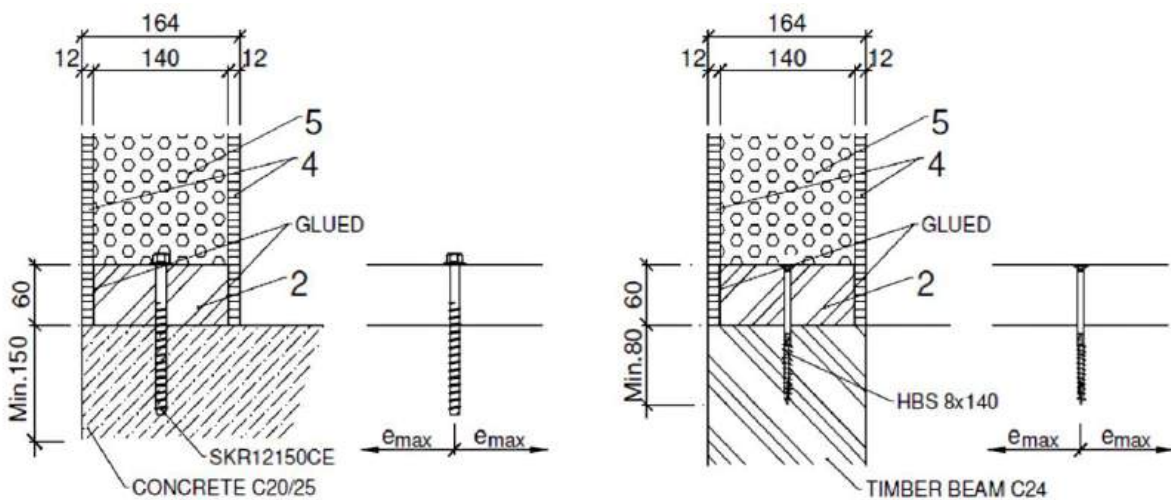

- Seal all panel joints with polyurethane or butyl-rubber sealant, as well as joints between panels and the external timber frame.
- Place two layers of roofing felt between the supporting timber frame and the surface of the concrete foundation.
- Cover the surface of the concrete foundation with two layers of bitumen mastics.

Examples for corner joints of Ecopan panels

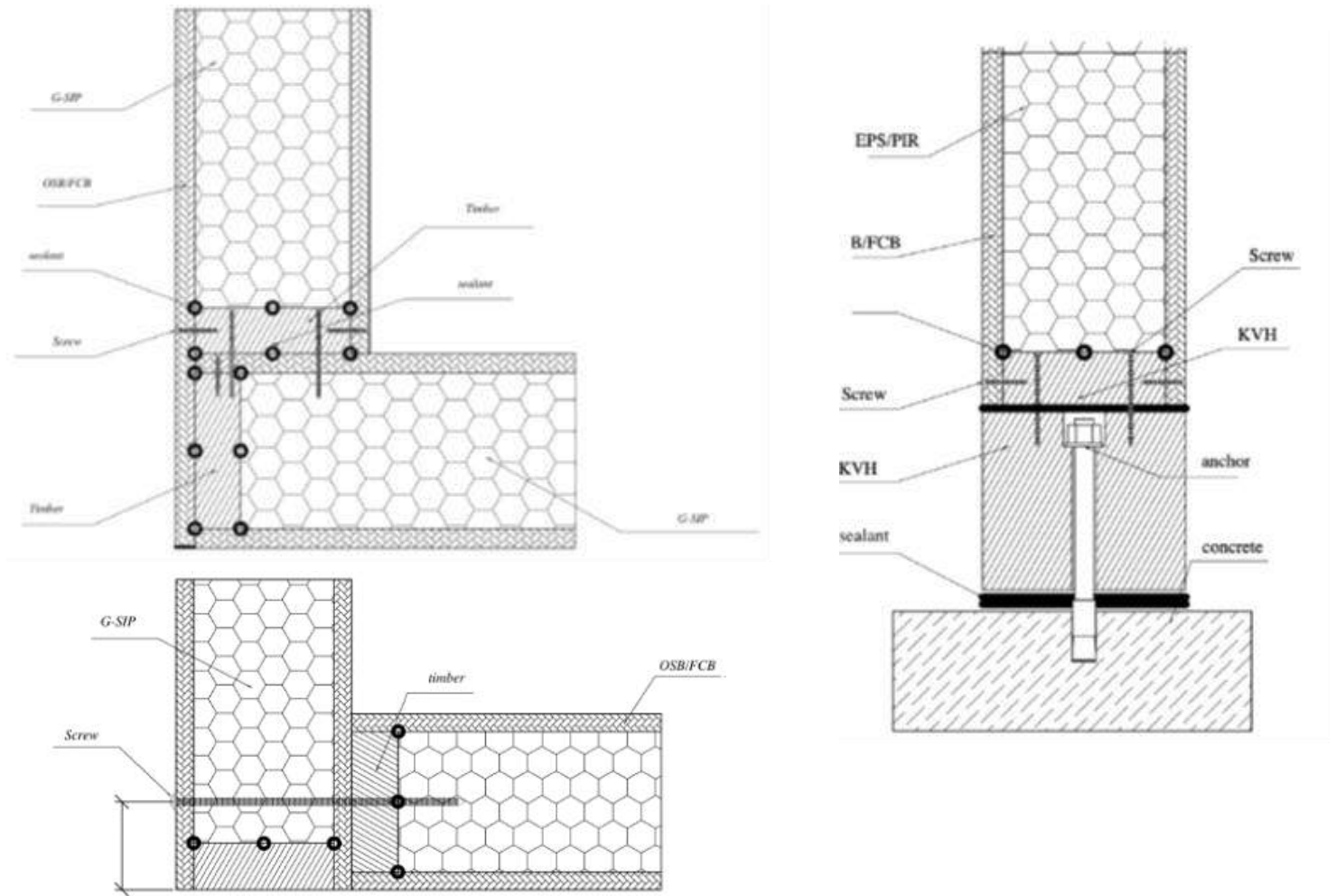

Roof details examples for Ecopan panels

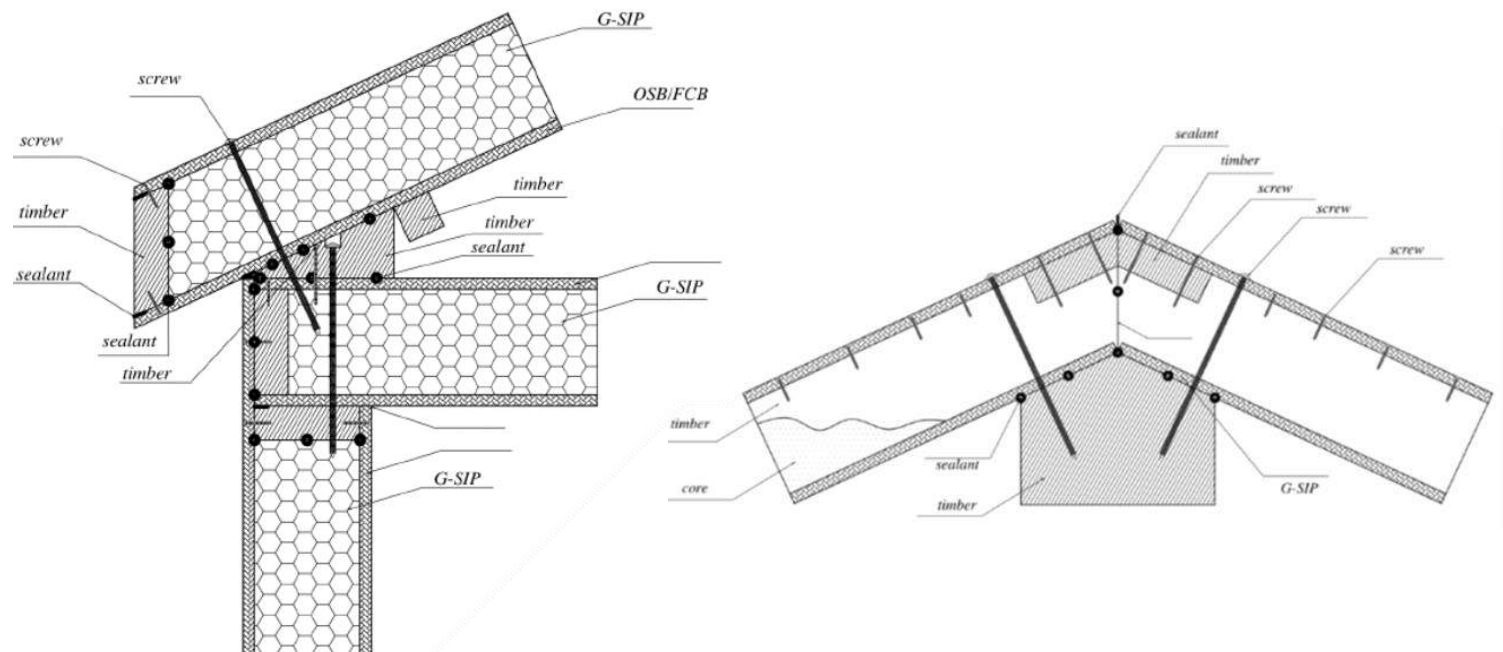



Thermal insulation panels and enclosing structures

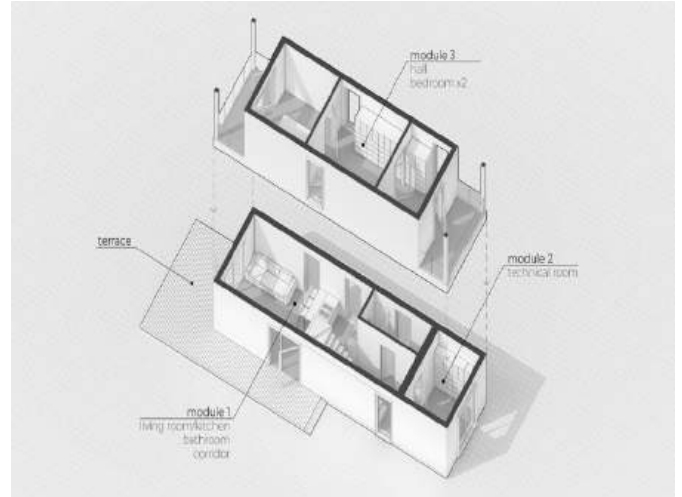

Pre-built SIP modules

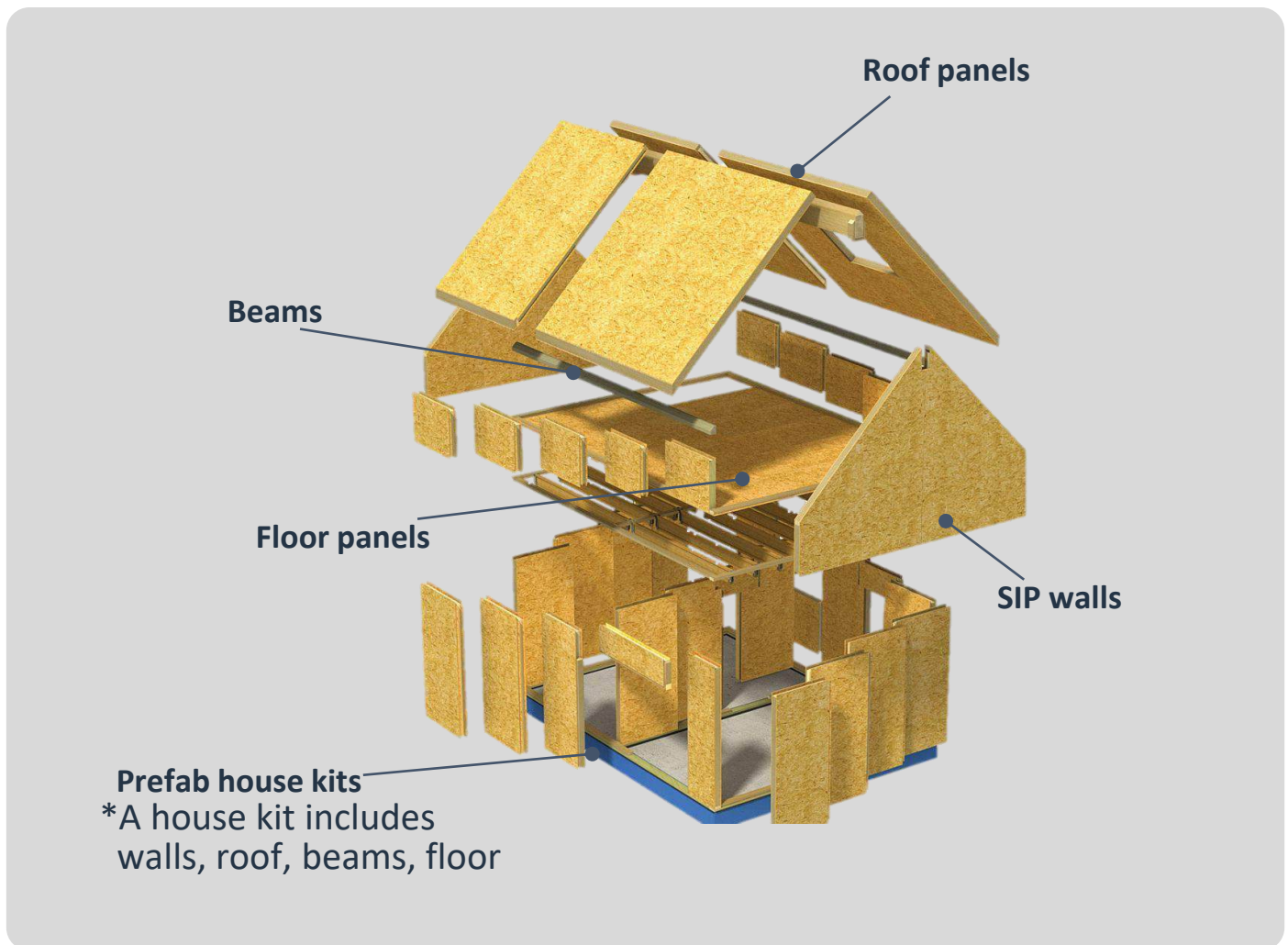

Standard Dimensions

Panels are manufactured with nominal **thicknesses from 110 mm to 270 mm**. Skins of panels are made of **10 mm, 12 mm and 15 mm thick OSB/3 oriented strand boards** (EGGER, Austria) or **10 mm, 12,5 mm and 15 mm thick gypsum fibre board** for structural use.

The core of panels is made of expanded polystyrene (EPS) produced by HIRSCH Porozell (Austria). Panels are manufactured in **widths ranging from 200 mm to a maximum of 1 250 mm**. **Length** (or height in case of walls) of standard panels is **2 800 mm**, maximum is up to 3 000 mm.

Skin boards are glued to insulation core by one component polyurethane adhesive (Everad, France) for structural use.

Find detailed specification of Ecopan panels below.

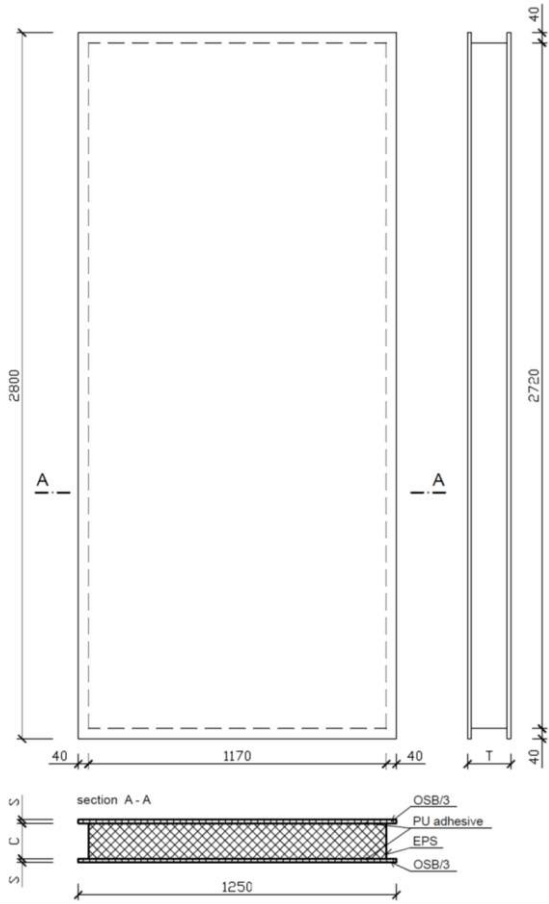

Standard Ecopan panel with OSB/3 skins, dimensions

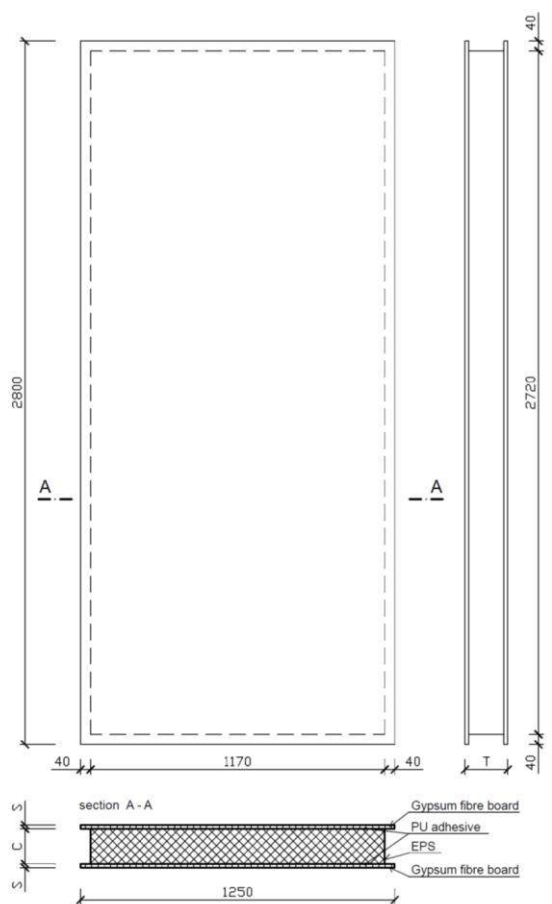

Standard Ecopan panel with gypsum fibre board skins, dimensions

Standard Ecopan panel with OSB/3 skins

Ecopan panel type	EPS core thickness C (mm)	OSB skin thickness S (mm)	Total panel thickness T (mm)	Recommended use
Ecopan 110	90	10	110	Internal walls
Ecopan 114		12	114	
Ecopan 120		15	120	
Ecopan 160	140	10	160	Internal and external walls
Ecopan 164		12	164	
Ecopan 170		15	170	
Ecopan 200	180	10	200	Internal, external walls and floors
Ecopan 204		12	204	
Ecopan 210		15	210	
Ecopan 260	240	10	260	Internal, external walls, floors and roofs
Ecopan 264		12	264	
Ecopan 270		15	270	

Standard Ecopan panel with gypsum fibre board skins

Ecopan panel type	EPS core thickness C, (mm)	Gypsum fibre board thickness S, (mm)	Total panel thickness T, (mm)	Recommended use
Ecopan 165 GFB	140	12,5	165	Internal walls and external walls
Ecopan 210 GFB	180	15	180	Internal walls, external walls and floors
Ecopan 270 GFB	240	15	240	

Structural Performance

SIPs create a lightweight yet robust structure that excels in handling in-plane loads. SIP buildings function akin to thin shell structures, distributing point loads across the entire surface area to improve structural performance.

Ecopan SIPs are designed to meet **loadbearing requirements, resist racking, and endure wind loading** based on the test results outlined in the Ecopan ETA

certification. The load-carrying capacities have been calculated in accordance with **EN 1995-1-1** and **EAD 140022-00-0304**. The data should be used for designs in accordance with **EN 1995-1-1**, **EN 1991-1-1**, **EN 1991-1-2** and **EN 1991-1-3** or an appropriate national code. Additional strength of panels can be achieved using structural engineering principles and introducing structural members such as ribs or posts within panels.

Find detailed load capacities of Ecopan panels below.

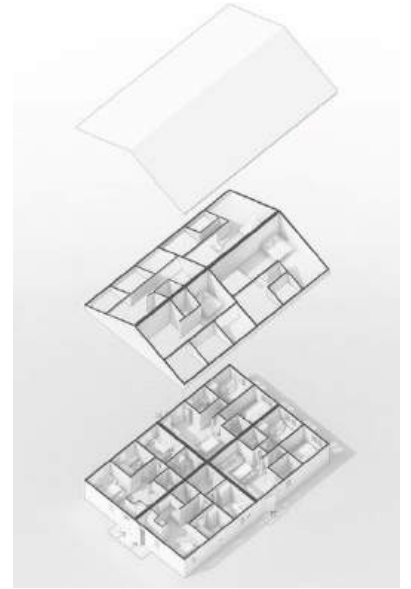

Load capacities of Ecopan wall panels

Load values of walls are calculated for service class 2 according to **EN 1995-1-1**. **Standard height** L_{max} of the Ecopan wall is **2 800 mm**. Calculation model is valid in case of undivided OSB/3 skins on both sides of Ecopan panels or gypsum fibre boards on both sides. Mechanical properties of insulation core used in the calculation model are given in the table below. Ecopan spline joints and spine joists are used in the calculation model. Ecopan spline joints and spine joists give same results of mechanical resistance. Load values are design values according to **EN 1995-1-1** and related EN standards. OSB/3 characteristic values according to **EN 12369-1**. Strength class of timber members is **C24 according to EN 338**.

Given modification, deformation and partial factors (k_{mod} , k_{def} , γ_m) shall be used in accordance to **EN 1995-1-1**, taking in account load duration and corresponding service class.

Design values of the mechanical resistance of Ecopan panels used walls

Mechanical resistance		Duration	Ecopan 164		Ecopan 165 GFB	
			Timber spline	Ecopan spline / spine	Timber spline	Ecopan spline / spine
Design bending moment	$M_{E,d}$ (kN·m)	Short-term	6,616	6,064	2,113	2,609
Compression resistance (buckling)	$N_{E,d}$ (kN·m ⁻¹)	Medium-term	69,021	19,021	58,377	12,884
Compression resistance in the support	$R_{E,d}$ (kN·m ⁻¹)	Medium-term	54,021	23,021	53,777	22,485
Shear resistance	$V_{E,d}$ (kN·m ⁻¹)	Short-term	6,720	6,720	6,720	6,720
Racking resistance (support concrete)	$H_{VE,d}$ (kN)	Short-term	4,500	-	4,500	-
<i>Racking resistance (support timber)</i>	$H_{VE,d}$ (kN)	Short-term	2,670	-	2,670	-
Service ability limit state; Service class 2; Short-term						
Bending instantaneous stiffness	$(EI)_{tot,ins}$ (N·m ⁻¹)	-	-	8,56E+05	-	6,92·10 ⁵
Shear instantaneous stiffness	$[(GA)_{inst}]^{-1}$ (N ⁻¹)	-	-	1,90E-06	-	1,88·10 ⁻⁶
Stiffness (Service class 2)						
Deformation factor of system	$k_{def,sys}$		1,41	1,41	2,04	2,04
Modification factor	k_{mod} , OSB skin		0,70 (short-term) 0,55 (medium-term)			
	k_{mod} , EPS core		1,00 (short-term) 0,75 (medium-term)			
	k_{mod} , Gypsum fibre board skin		0,60 (short-term) 0,45 (medium-term)			
Deformation factor	k_{def} , OSB skin		1,50			
	k_{def} , EPS core		7,00			
	k_{def} , Gypsum fibre board skin		4,00			
Partial factor for material properties	γ_m , OSB skin		1,20			
	γ_m , EPS core		1,25			
	γ_m , Gypsum fibre board skin		1,30			

Note 1 - Serviceability Limit State (deformations) was taken into account in calculation of the loadbearing capacity.

Note 2 - Self-load of the panel is g_d included in calculation. Values valid for insulation core made of EPS 100.

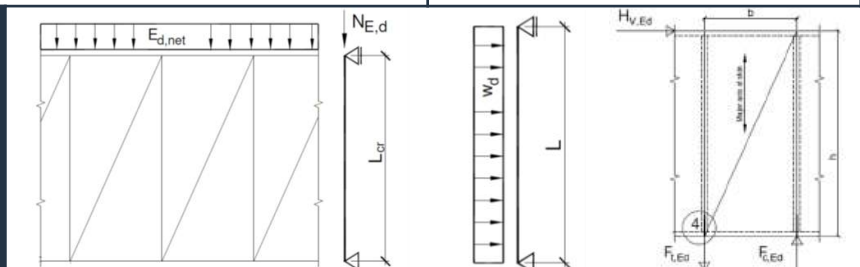

Load capacities of Ecopan floors and ceilings

Load values of floors and ceilings are calculated for service class 1 according to EN 1995-1-1. Maximum span between supports is 1 250 mm. Calculation model is valid in case of undivided skins on both sides of Ecopan panels. Mechanical properties of insulation core used in the calculation model are given in the table below. Ecopan spline joints and spine joists are used in the calculation model. Ecopan spline joints and spine joists give same results of mechanical resistance.

Load values are design values according to EN 1995-1-1 and related EN standards. Self-load of the panel is included in calculation. **OSB/3** characteristic values according to EN 12369-1. Strength class of **timber** members is **C24** according to EN 338.

Given modification, **deformation and partial factors** (k_{mod} , k_{def} , γ_m) shall be used in accordance to EN 1995-1-1, taking in account load duration and corresponding service class.



Design values of the mechanical resistance of Ecopan panels used in floors

Mechanical resistance		Duration	ECOPAN 210		ECOPAN 210 GFB	
			Timber spline	ECOPAN spline	Timber spline	ECOPAN spline
Design bending moment	$M_{E,d}$ (kN·m)	Medium-term	12,000	11,393	3,150	3,969
Compression resistance (buckling)	$N_{E,d}$ (kN·m ⁻¹)	Medium-term	80,000	34,400	60,000	28,800
Compression resistance in the support	$R_{E,d}$ (kN·m ⁻¹)	Medium-term	26,267	26,267	23,530	26,267
Horizontal resistance in the support	$H_{E,d}$ (kN·m ⁻¹)	Medium-term	10,160	10,160	10,160	10,160
Shear resistance	$V_{E,d}$ (kN'·m ⁻¹)	Medium-term	8,420	7,980	8,400	8,084
Service ability limit state; Service class 1; Medium-term						
Bending instantaneous stiffness	$(EI)_{tot,ins}$ (N·m ²)		-	1,76.10 ⁶	-	1,36.10 ⁶
Bending final stiffness	$(EI)_{tot,fin}$ (N·m ²)		-	7,04.10 ⁵	-	3,39.10 ⁵
Shear instantaneous stiffness	$[(GA)_{inst}]^{-1}$ (N ⁻¹)		-	1,482.10 ⁻⁶	-	1,482.10 ⁻⁶
Shear final stiffness	$[(GA)_{fin}]^{-1}$ (N ⁻¹)		-	1,186.10 ⁻⁵	-	4,595.10 ⁻⁵
Stiffness (Service class 1)						
Deformation factor of system	$k_{def,sys}$		1,04	-	1,55	-
Modification factor	k_{mod} , OSB skin	0,70 (medium-term)				
	k_{mod} , EPS core	0,75 (medium-term)				
	k_{mod} , Gypsum fibre board skin	0,60 (medium-term)				
Deformation factor	k_{def} , OSB skin	1,50				
	k_{def} , EPS core	7,00				
	k_{def} , Gypsum fibre board skin	3,00				
Partial factor for material properties	γ_m , OSB skin	1,20				
	γ_m , EPS core	1,25				
	γ_m , Gypsum fibre board skin	1,30				

Note 1 - Serviceability Limit State (deformations) was taken into account in calculation of the loadbearing capacity.

Note 2 - Self-load of the panel is g_d included in calculation. Values valid for insulation core made of EPS 100.

Load capacities of Ecopan roofs

Load values of roofs are calculated for service class **2** according to **EN 1995-1-1**. Maximum **span** between supports is **1 250 mm**. Calculation model is valid in case of undivided skins on both sides of Ecopan panels. Mechanical properties of insulation core used in the calculation model are given in the table below. Ecopan spline joints and spine joists are used in the calculation model. Ecopan spline joints and spine joists give same results of mechanical resistance.

Load values are design values according to **EN 1995-1-1** and related EN standards. Self-load of the panel is included in calculation. **OSB/3** characteristic values according to **EN 12369-1**. Strength class of **timber** members is **C24** according to **EN 338**.

Given modification, **deformation and partial factors** (k_{mod} , k_{def} , γ_m) shall be used in accordance to **EN 1995-1-1**, taking in account load duration and corresponding service class.



Design values of the mechanical resistance of ECOPAN panels used in roofs, slope/pitch 0°

Mechanical resistance		Duration	ECOPAN 270		ECOPAN 270 GFB	
			Timber spline	ECOPAN spline	Timber spline	ECOPAN spline
Design bending moment	$M_{E,d}$ (kN·m)	Medium-term	14,000	12,863	3,750	3,969
Compression resistance (buckling)	$N_{E,d}$ (kN·m ⁻¹)		100 000	37,600	77,916	26,400
Compression resistance in the support (perpendicular to the skin)	$R_{E,d}$ (kN·m ⁻¹)		26,267	26,267	26,267	26,267
Horizontal resistance in the support (parallel with skin)	$H_{E,d}$ (kN·m ⁻¹)		20,000	20,000	20,000	20,000
Shear resistance	$V_{E,d}$ (kN·m ⁻¹)		9,600	9,450	9,600	9,450
Service ability limit state; Service class 2; Medium-term						
Bending instantaneous stiffness	$(EI)_{tot,ins}$ (N·m ²)	-	3,01.10 ⁶	-	2,32E+06	
Bending final stiffness	$(EI)_{tot,fin}$ (N·m ²)	-	9,26.10 ⁵	-	4,64E+05	
Shear instantaneous stiffness	$[(GA)_{inst}]^{-1}$ (N ⁻¹)	-	9,245.10 ⁻⁶	-	1,156.10 ⁻⁶	
Shear final stiffness	$[(GA)_{fin}]^{-1}$ (N ⁻¹)	-	3,582.10 ⁻⁶	-	9,245.10 ⁻⁶	
Stiffness (Service class 2)						
Deformation factor of system	$k_{def,sys}$	1,34	-	1,75	-	
Modification factor	k_{mod} , OSB skin	0,70 (short-term) 0,55 (medium-term)				
	k_{mod} , EPS core	0,75 (medium-term)				
	k_{mod} , Gypsum fibre board skin	0,60 (short-term) 0,45 (medium-term)				
Deformation factor	k_{def} , OSB skin	1,50				
	k_{def} , EPS core	7,00				
	k_{def} , Gypsum fibre board skin	4,00				
Partial factor for material properties	γ_m , OSB skin	1,20				
	γ_m , EPS core	1,25				
	γ_m , Gypsum fibre board skin	1,30				

Note 1 - Serviceability Limit State (deformations) was taken into account in calculation of the loadbearing capacity.

Note 2 - Self-load of the panel is g_d included in calculation. Values valid for insulation core made of EPS 100

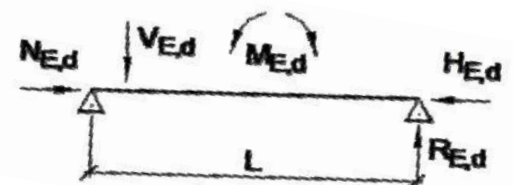

Design values of the mechanical resistance of ECOPAN panels used in roofs, slope/pitch 15°

Mechanical resistance		Duration	ECOPAN 270		ECOPAN 270 GFB		
			Timber spline	ECOPAN spline	Timber spline	ECOPAN spline	
Design bending moment	$M_{E,d}$ (kN·m)	Medium-term	14,000	12,863	3,750	3,969	
Compression resistance (buckling)	$N_{E,d}$ (kN·m ⁻¹)		100,000	37,600	77,916	26,400	
Compression resistance in the support (perpendicular to the skin)	$R_{E,d}$ (kN·m ⁻¹)		26,267	26,267	26,267	26,267	
Horizontal resistance in the support (parallel with skin)	$H_{E,d}$ (kN·m ⁻¹)		20,00	20,000	20,00	20,000	
Shear resistance	$V_{E,d}$ (kN·m ⁻¹)		9,600	9,450	9,600	9,450	
Combination of	Design bending moment		$M_{E,d}$ (kN·m)	13,500	10,106	3,750	3,675
	compression resistance (buckling)		$N_{E,d}$ (kN·m ⁻¹)	8,000	6,400	8,000	8,000

Service ability limit state; Service class 2; Medium-term

Bending instantaneous stiffness	$(EI)_{tot,ins}$ (N·m ²)	-	3,01.10 ⁶	-	2,32E+06
Bending final stiffness	$(EI)_{tot,fin}$ (N·m ²)	-	9,26.10 ⁵	-	4,64E+05
Shear instantaneous stiffness	$[(GA)_{inst}]^{-1}$ (N ⁻¹)	-	9,245.10 ⁻⁶	-	1,156.10 ⁻⁶
Shear final stiffness	$[(GA)_{fin}]^{-1}$ (N ⁻¹)	-	3,582.10 ⁻⁶	-	9,245.10 ⁻⁶

Stiffness (Service class 2)

Deformation factor of system	$k_{def,sys}$	1,34	-	1,75	-
Modification factor	k_{mod} , OSB skin	0,70 (short-term) 0,55 (medium-term)			
	k_{mod} , EPS core	1,00 (short-term) 0,75 (medium-term)			
	k_{mod} , Gypsum fibre board skin	0,60 (short-term) 0,45 (medium-term)			
Deformation factor	k_{def} , OSB skin	1,50			
	k_{def} , EPS core	7,00			
	k_{def} , Gypsum fibre board skin	4,00			
Partial factor for material properties	γ_m , OSB skin	1,20			
	γ_m , EPS core	1,25			
	γ_m , Gypsum fibre board skin	1,30			

Note 1 - Serviceability Limit State (deformations) was taken into account in calculation of the loadbearing capacity.

Note 2 - Self-load of the panel is g_d included in calculation. Values valid for insulation core made of EPS 100.

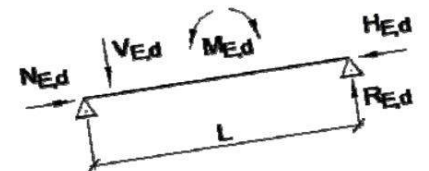

Design values of the mechanical resistance of ECOPAN panels used in roofs, slope/pitch 30°

Mechanical resistance		Duration	ECOPAN 270		ECOPAN 270 GFB		
			Timber spline	ECOPAN spline	Timber spline	ECOPAN spline	
Design bending moment	$M_{E,d}$ (kN·m)	Medium-term	14,000	12,863	3,750	3,969	
Compression resistance (buckling)	$N_{E,d}$ (kN·m ⁻¹)		100,000	37,600	77,916	26,400	
Compression resistance in the support (perpendicular to the skin)	$R_{E,d}$ (kN·m ⁻¹)		26,267	26,267	26,267	26,267	
Horizontal resistance in the support (parallel with skin)	$H_{E,d}$ (kN·m ⁻¹)		20,000	20,000	20,000	20,000	
Shear resistance	$V_{E,d}$ (kN·m ⁻¹)		9,600	9,450	9,600	9,450	
Combination of	Design bending moment		$M_{E,d}$ (kN·m)	13,000	9,184	3,700	3,491
	compression resistance (buckling)		$N_{E,d}$ (kN·m ⁻¹)	12,000	8,000	16,000	12,000

Service ability limit state; Service class 2; Medium-term

Bending instantaneous stiffness	$(EI)_{tot,ins}$ (N·m ²)	-	3,01.10 ⁶	-	2,32E+06
Bending final stiffness	$(EI)_{tot,fin}$ (N·m ²)	-	9,26.10 ⁵	-	4,64E+05
Shear instantaneous stiffness	$[(GA)_{inst}]^{-1}$ (N ⁻¹)	-	9,245.10 ⁻⁶	-	1,156.10 ⁻⁶
Shear final stiffness	$[(GA)_{fin}]^{-1}$ (N ⁻¹)	-	3,582.10 ⁻⁶	-	9,245.10 ⁻⁶

Stiffness (Service class 2)

Deformation factor of system	$k_{def,sys}$	1,34	-	1,75	-
Modification factor	$k_{mod, OSB skin}$	0,70 (short-term) 0,55 (medium term)			
	$k_{mod, EPS core}$	1,00 (short-term) 0,75 (medium-term)			
	$k_{mod, Gypsum fibre board skin}$	0,60 (short-term) 0,45 (medium-term)			
Deformation factor	$K_{def, OSB skin}$	1,50			
	$k_{def, EPS core}$	7,00			
	$k_{def, Gypsum fibre board skin}$	4,00			
Partial factor for material properties	$\gamma_m, OSB skin$	1,20			
	$\gamma_m, EPS core$	1,25			
	$\gamma_m, Gypsum fibre board skin$	1,30			

Note 1 - Serviceability Limit State (deformations) was taken into account in calculation of the loadbearing capacity.

Note 2 - Self-load of the panel is g_d included in calculation. Values valid for insulation core made of EPS 100.

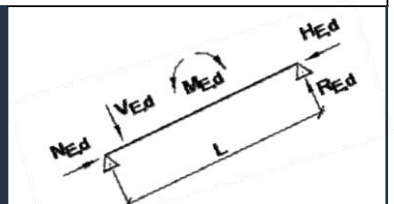

Natural Durability

Panels can be used in service **classes 1 and 2** according to **EN 1995-1-1** and **EN 335**. The products may be exposed directly to the weather for a short time during installation.

OSB/3 boards were assessed to have satisfactory durability for intended use in use **classes 1 and 2** according to **EN 335**.

Natural durability of wood components and fasteners to be found in Ecopan's ETA certificate.

Thermal Performance

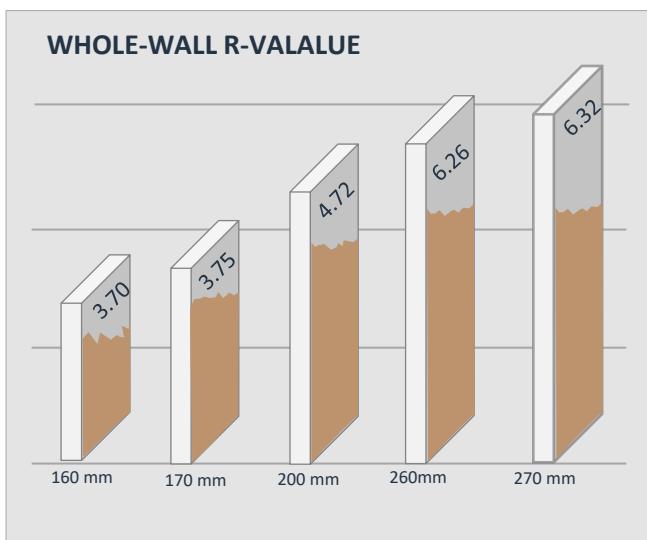

Insulation is crucial for energy-efficient homes and buildings. With heating and cooling constituting 50% of average home energy use, quality insulation can yield significant cost savings. Ecopan panels enhance thermal performance, promoting energy efficiency.

Insulation's effectiveness is measured by **R-value**, indicating thermal resistance.

SIP walls surpass traditional stud walls in providing higher R-values, offering superior insulation. However, R-value alone doesn't capture real-world performance. SIPs, with continuous insulation, outperform fiberglass by maintaining stated R-values throughout a home's lifespan.

Considerations like **thermal bridging**, where wood elements transfer heat, are vital. **SIP construction minimizes thermal bridging** compared to traditional stick frame construction, which uses more wood framing.

Ecopan are able to produce various thicknesses of panel this allowing us to achieve very low **u-values**, our u-values can range from **0,29W/m².K down to 0.15W/m².K**, find detailed u-value table for different performances below.

Example of SIP Wall with Inner and Outer Finish

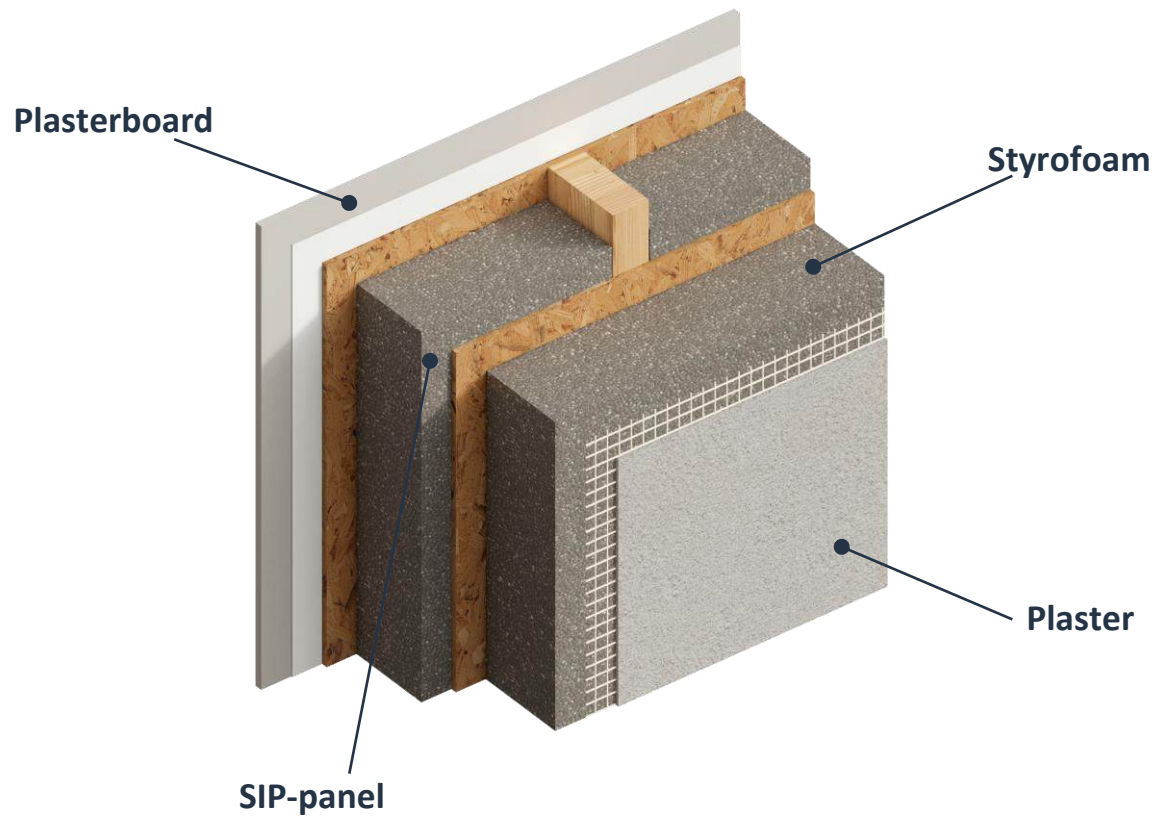

The sections shows the optimal structure of a SIP wall to achieve thermal performance

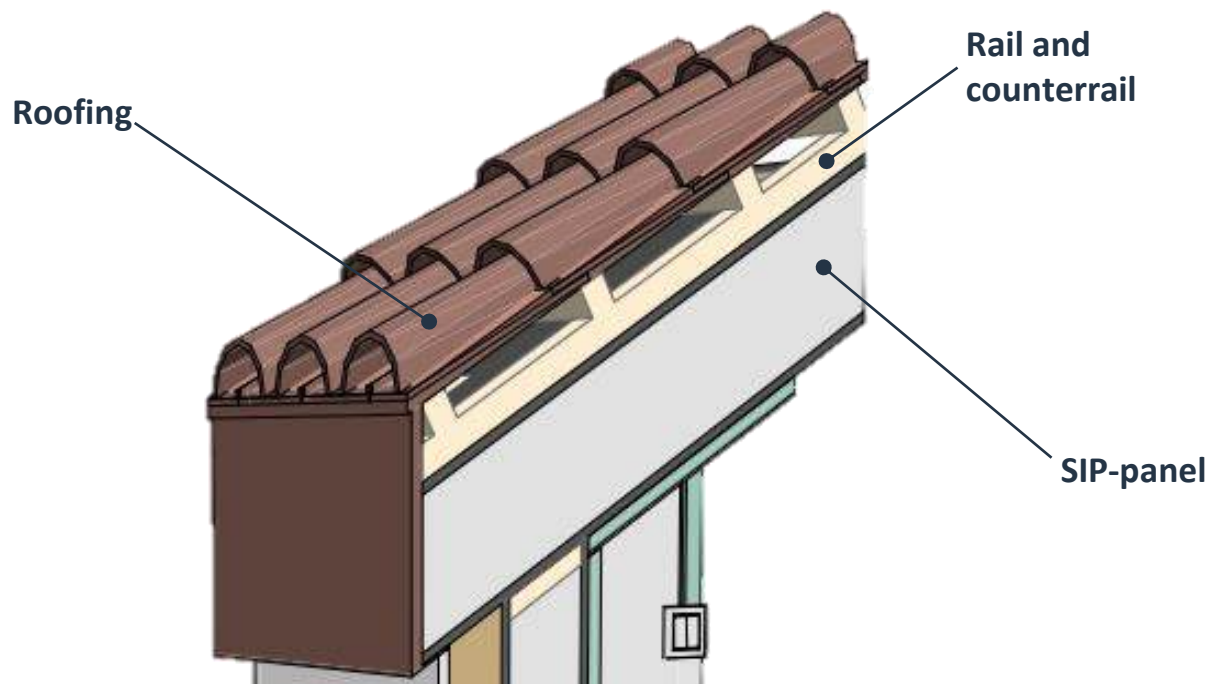

Thermal resistance and thermal transmittance of Ecopan panels (joist spacing 1 250 mm)

Ecopan panel type	Type of connection	Thermal resistance R ($m^2 \cdot K/W$)	Used as exterior wall	Used as roof or floor over the unheated space
			Thermal transmittance U ($W/m^2 \cdot K$)	Thermal transmittance U ($W/m^2 \cdot K$)
Ecopan 160	Timber	3,29	0,287	–
	Ecopan spline	3,70	0,259	–
Ecopan 164	Timber	3,33	0,285	–
	Ecopan spline	3,72	0,257	–
Ecopan 170	Timber	3,38	0,281	–
	Ecopan spline	3,75	0,255	–
Ecopan 200	Timber	4,19	0,229	0,230
	Ecopan spline	4,72	0,204	0,206
Ecopan 204	Timber	4,22	0,227	0,229
	Ecopan spline	4,74	0,203	0,205
Ecopan 210	Timber	4,27	0,224	0,226
	Ecopan spline	4,78	0,202	0,203
Ecopan 260	Timber	5,53	0,175	0,176
	Ecopan spline	6,26	0,155	0,156
Ecopan 264	Timber	5,56	0,174	0,175
	Ecopan spline	6,28	0,155	0,156
Ecopan 270	Timber	5,61	0,173	0,173
	Ecopan spline	6,32	0,154	0,155
Ecopan 165 GFB	Timber	3,21	0,294	0,297
	Ecopan spline	3,60	0,265	0,268
Ecopan 210 GFB	Timber	4,12	0,232	0,234
	Ecopan spline	4,64	0,208	0,209
Ecopan 270 GFB	Timber	5,46	0,177	0,178
	Ecopan spline	6,18	0,158	0,158

NOTE – The R values are calculated without R_{si} and R_{se} values. U values are calculated with appropriate R_{si} and R_{se} values for walls and roofs/floors according to EN ISO 6946.

Air Tightness and Ventilation

SIP structures, whether residential or commercial, offer precise control over indoor air quality. The airtight building envelope ensures controlled ventilation, effectively filtering out contaminants and allergens. Unlike conventional stick framing with voids and thermal bridging, SIPs eliminate condensation risks, preventing potential hazards like mold, mildew, or rot. Ventilation is crucial for a healthy living environment, impacting well-being, comfort, and ambiance. Healthy buildings typically require a minimum of 0.5 air changes per hour (m³/m²hr). **SIP systems, with their superior airtightness, outperform traditional constructions, so developers should pay serious attention to ventilation methods.**

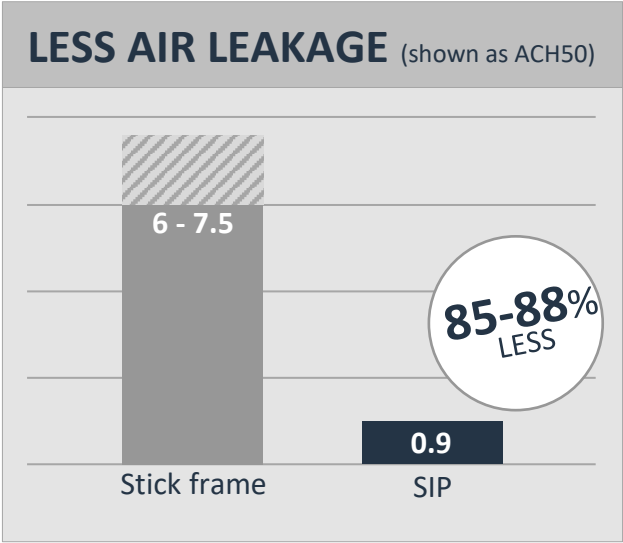

Fire Performance

SIPs adhere to the EU Construction Products Regulation for fire resistance when equipped with plasterboard, mirroring standards applicable to timber frame construction. A single layer ensures a **30-minute rating**, while a double layer achieves a **60-minute rating**.

Ecopan uses materials and components that are conform to:

Component / Material	Reaction to fire class	
OSB boards	D-s2, d0	EN 13986 2003/43/EC ¹⁾
Structural timber	D-s2, d0	EN 14081-1 2003/43/EC ¹⁾
Structural finger jointed solid timber (KVH)	D-s2, d0	EN 15497 2003/43/EC ¹⁾
Expanded polystyrene (EPS)	E	EN 13501-1
Gypsum fibre board for structural use	A2	EN 13501-1

Acoustic Performance



SIPs provide outstanding acoustic performance, and sound resistance levels depend on the system build-up, external finish, and the thickness of the insulating foam core. Ecopan can provide guidance on optimal system components for achieving specific acoustic goals. When enhanced sound insulation performance is necessary, employing multiple layers of acoustic-rated plasterboard is a common practice. Consulting with an acoustic expert can help define specifications and performance requirements.

A standard Ecopan panel configuration boasts a sound transmission rating of **RW 55 dB**. This can be enhanced to **RW 60-62 dB** by adding an extra

gypsum layer on one or both sides. When employed as an external panel behind brick cladding, the performance surpasses **RW 70 dB**. The physical isolation of inner and outer boards contributes to outstanding resistance against both airborne and impact noise.

Intended Working Life of the Construction Product and Warranty

5

YEARS
service warranty

Provisions made in this European Technical Assessment are based on an assumed **intended working life of panels of 50 years**. The indications given on the working life cannot be interpreted as a guarantee given by Ecopan but are to be regarded only as a means for choosing the appropriate product in relation to the expected, economically reasonable working life of the works.

Ecopan typically provides up to **5 years of warranty** on its products. To get more tailored information on Ecopan's warranty obligations, please get in touch with us through contacts on the last page.

SIP Manufacturing Within the EU

Ecopan's brand-new Romanian facility operates under rigorous adherence to all EU regulations, guaranteeing the latest standards in environmental sustainability and production excellence.

Modern production of SIP panels ensures high product quality, it's efficiency and precision of dimensions

EU regulations compliant (meets all current EU requirements)

Convenient logistics within the EU



Technický a skúšobný ústav stavebný, n. o.



Technický a skúšobný ústav stavebný, n. o.
Building Testing and Research Institute
Štefánikova 3
821 04 Bratislava
Slovak Republic
Phone: +421 2 43221011
E-mail: skusobna@tus.sk
Website: www.tus.sk



Overordnet
ansvarlig
Anette Thiel
Rindaker (EU)
16.03.2011



Member of
ETA
www.eta.eu

European Technical Assessment
ETA 22/058 – version 02 of 03/10/2023

General Part

Technical Assessment Body issuing the ETA and designated according to Article 29 of the Regulation (EU) No 305/2011: Technický a skúšobný ústav stavebný, n. o.

Trade name of the construction product: ECOPAN panels

Product family to which the construction product belongs: Product area code: 14 WOOD BASED PANELS AND ELEMENTS

Manufacturer: ECOPAN EUROPE S.R.L.
Bala Mare, Str. Victoriei Nr. 59A/17-18, Maramures, Romania

Manufacturing plant: ECOPAN EUROPE S.R.L.
Ulmeni, Str. Petre Dulfu Nr. 121, Maramures, Romania

This European Technical Assessment contains: 24 pages including 4 annexes which form an integral part of this assessment.

This European Technical Assessment is issued in accordance with regulation (EU) No 305/2011, on the basis of: EAD 140022-00-0304: November 2015, Prefabricated wood-based loadbearing stressed skin panels

This version replaces: —

Translations of this European Technical Assessment in other languages shall fully correspond to the original issued document and should be identified as such.

Page 1 of 24 of European Technical Assessment ETA XXXXXX – 01 – 2023-XX-XX



EPS 100 LAMBDAroof **TECHNICAL FILE**

Description:

- EPS 100 LAMBDAroof is a granitic polystyrene with improved thermal conductivity with about 20% (λ 023 instead of 0.030 W/mK) compared to EPS 100.
- Polystyrene film, rectangular, with smooth surface, without unevenness and dimensional deviations other than those prescribed.
- Stress-relieved film that will not "work" over time, avoiding the formation of cracks.

Utilisation field:

Special product, intended for use in composite external thermal insulation systems (ETICS) of facades, according to SR EN 13490 2004

- Insulation of pitched roofs, under roof coatings.
- Thermal insulation of unobstructed terraces.
- Thermal insulation of floors under screeds or reinforced concrete slabs.
- Cold room insulation.

Technical characteristics:

Parameter	Class	Value	Determination method
Limit deviation for length (mm)	L2	±2	SR EN 1022/97
Limit deviation for thickness (mm)	T1	±1	SR EN 623/97
Limit deviation for height (mm)	H2	±2	SR EN 1022/97
Limit deviation for perpendicularity (mm/m)	Sb2	±2	SR EN 1024/97
Limit deviation for flatness (mm)	F2	3	SR EN 1025/97
Dimensional stability under specific temperature and humidity conditions (%)	DSb7,11	±1	SR EN 1015/98
Bonding strength (kPa)	BS 150	≥150	SR EN 12269/09
Compressive strength at a deformation of 10% (kPa)	CS(10/100)	≥100	SR EN 1029/96
Dimensional stability under constant laboratory conditions (%)	DSb12	±0.2	SR EN 1003/96
Deformation under specified compressive load and temperature conditions (%)	DLT1/5	±5	SR EN 1603/99
Tensile strength perpendicular to face (kPa)	TR1/5	≥150	SR EN 1007/99
Long-term water absorption by total immersion (%)	WLT/3	±3	SR EN 12067/09
Long-lasting water absorption by partial immersion (kg/m ²)	Wp	≤0.5	SR EN 12067/09
Compressibility (mm)	CP5	±5	SR EN 12431/02
Declared thermal conductivity λD 10 °C (W/mK)	-	0.028	SR EN 12667/02
Resistance to water vapour diffusion	µ - thermal factor	36 - 70	SR EN 12067/09
	µ - permeability at water vapour entry Pa/(m ² h)	0.010 - 0.024	
Reaction to fire class-compliant to BREEN 13501-1+A52010	Class E		SR EN 11925-2

Advantages:

- Provides superior thermal insulation compared to traditional polystyrene products, even with reduced thicknesses.
- No cracks formed, even with thick insulation.
- The product is superior elasticity and is 100% recyclable.
- Flame and good water vapor diffusion capacity due to its open microstructure, allowing water vapor to migrate to the outside of the thermal envelope of the building.
- It considerably reduces heat loss in the home by mitigating the effect of heat energy transfer through infrared radiation.

Certification:

- The product is certified in accordance with the requirements of SR EN 13163:2013+A1:2015, system 3 attestation of conformity - Annex ZA.
- The product is subject to an integrated management system according to ISO 9001:2015 and ISO 14001:2015.

Installation:

- It is carried out in accordance with national or European regulations and technical guidelines or a process certified by a notified body. In the case of the use of granitic polystyrene for the cladding of buildings, the facades must be protected with solar protection curtains until the work is completed.

Transport and storage:

- Storage should be in a dry place away from prolonged exposure to direct sunlight.
- Storage near heat or fire sources is prohibited and contact with combustible petroleum products should be avoided.
- The product must be kept in its original packaging until it is put into service, avoiding storage on the edge of the site.
- Transport should be carried out by suitably trained means of transport, away from heat-generating components or vehicle sparks.

Guarantee terms:

- The manufacturer guarantees the physical characteristics of the manufactured products as follows:
- Commercial guarantee: 24 months (Law 449/2003), provided the storage - handling requirements are met.
- Conformity guarantee: 10 years (Law 10/1995) from receipt of commissioning, in accordance with the law and the applications recommended by the manufacturer.

July 2023

S.C. SWISSPOR S.R.L.
Pinerol, Strada de Centura Pinerol Est
Tel: +41 244 542 318 Fax: +41 244 543 421
Mobile: +41 712 789 720
Email: info@swisspor.ch

S.C. SWISSPOR SRL
Cluj-Napoca, Calea Bacului Nr. 1-3
Tel: +41 264 425 937 Fax: +41 264 456 888
Mobile: +41 741 844 437
Email: office@swisspor.ro

www.swisspor.ro



CERTIFICATE

N° CSM/EVE002-004

certifies that:

EVERAD ADHESIVES

Parc d'Activités de Mossig - 67520 MARLENHEIM

operates a management system that has been assessed as conforming to:

ISO 9001 : 2015 - ISO 14001 : 2015



for the scope of activities:

Develops, produces, packs, and distributes innovative bonding solutions in the markets of cellular foam adhesives, construction, assembly and toll manufacturing.

Issue date: 22/01/2021
Valid until: 21/01/2024 (subject to adherence to the agreed copying programme, successful achievement of certification following each audit and compliance with the terms and conditions of certification)

Gillesime REY Director, Operations



CSN_F03N_015 - V2.0 CG-21122017-FR-ER



THE INTERNATIONAL CERTIFICATION NETWORK

CERTIFICATE

Quality Austria has issued an IQNet recognized certificate that the organization:

Fritz Egger GmbH & Co. OG.

A-6380 St. Johann, Weiberndorf 20

Sites; see Appendix

for the following scope:

Production of wood-based materials, laminates, glues and impregnation resins, recycling
EAC: B, 35.1

has implemented and maintains a

QUALITY MANAGEMENT SYSTEM

which fulfils the requirements of the following standard

ISO 9001:2015

Issued on: 2018-08-27

Validity date: 2021-08-28

Quality Austria certified since: 1994-03-22

This attestation is directly linked to the IQNet Partner's original certificate and shall not be used as a stand-alone document.

Registration Number: AT-00184/0



Alex Stoichitu
President of IQNet



Mag. Friedrich Khuen-Belasi
Authorised Representative of Quality Austria



* The list of IQNet partners is held at the office of the president. Updated information is available under www.iqnet-certification.com

VGO Bautraeger GmbH

SIP-Bautechnologie

Mehr Informationen finden Sie auf:

www.vgo-bau.at

E-Mail: office@vgo-bau.at

Telefon: +43 650 3618479

VGO Bautraeger GmbH
Akkonplatz 1, 1150 Wien, Oesterreich

Ihr Berater vor Ort: Omer Murati - Geschaeftsfuehrer